



GARANTIE DEUTSCH

Für das vorliegende Gerät übernimmt JBC eine Garantie von 2 Jahre, für alle Fabrikationsfehler. Diese Garantie schliesst die Reparatur bzw. den Ersatz der defekten Teile sowie die entsprechenden Arbeitskosten ein.

Ausgeschlossen von dieser Garantieleistung sind durch unsachgemässen Gebrauch hervorgerufene Betriebsstörungen.

Zur Inanspruchnahme dieser Garantie muss das Gerät portofrei an den Vertriebs Händler geschickt werden, bei dem es gekauft wurde. Fügen Sie dieses vollständig, ausgefüllte Blatt, bei.

GARANZIA ITALIANO

La JBC garantisce quest'apparato 2 anni contro ogni difetto di fabbricazione, e copre la riparazione e la sostituzione dei pezzi difettosi, includendo la mano d'opera necessaria.

Sono escluse da questa garanzia le avarie provocate da cattivo uso dell'apparato.

Per usufruire di questa garanzia, è indispensabile inviare, in porto franco, l'apparato al distributore presso il quale è stato acquistato, unitamente a questo foglio debitamente compilato.

SERIAL N°

STAMP OF DEALER
SELLO DEL DISTRIBUIDOR
CACHET DU DISTRIBUTEUR
STEMPEL DES HÄNDLERS
TIMBRO DEL DISTRIBUTORE

DATE OF PURCHASE
FECHA DE COMPRA
DATE D'ACHAT
KAUFDATUM
DATA DI ACQUISTO

AD 2200

Control Unit 230V 50Hz EU Ref. 2200200
Control Unit 230V 50Hz UK Ref. 2200201
Control Unit 120V 60Hz US Ref. 2200100

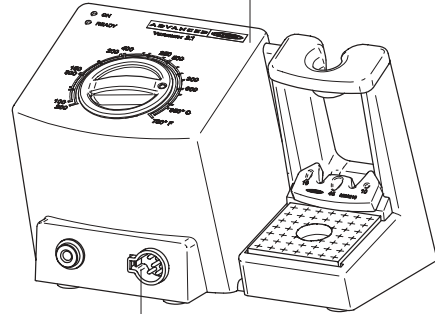

2210 Handpiece

2245 Handpiece

Structure of Advanced soldering stations system

The Advanced series has basic modules giving you full flexibility for choosing what you need for the work in hand, the modules being supplied separately.

Control unit

- AD 2200

Double control unit

- AD 4200

Handpieces

- 2210 and 2245

Cartridges

- Range of cartridges 2210 and 2245.

Stand

- Soldering iron stand AD 8200 Ref. 0268200

For a station to work properly, a control unit, a handpiece and one cartridge are needed. The soldering iron stand is necessary to connect the handpieces to the AD 4200, AR 5500 and AM 6000 stations.

Cartridges

2210

See overleaf for range

Cartridges

2245

See overleaf for range

2210 Handpiece Ref. 2210000. Power: 20W. For high precision work, SMD, etc.

2245 Handpiece Ref. 2245000. Power: 50W. For general soldering work.

The handpieces and cartridges **2210** and **2245** comply with the MIL-SPEC-2000 referring to the potential difference between the soldering tip and ground connection, must be less than 2 mV.

The handpieces **2210** and **2245** can be connected to the following JBC stations:

AD 2200, AD 4200, AR 5500 and AM 6000.

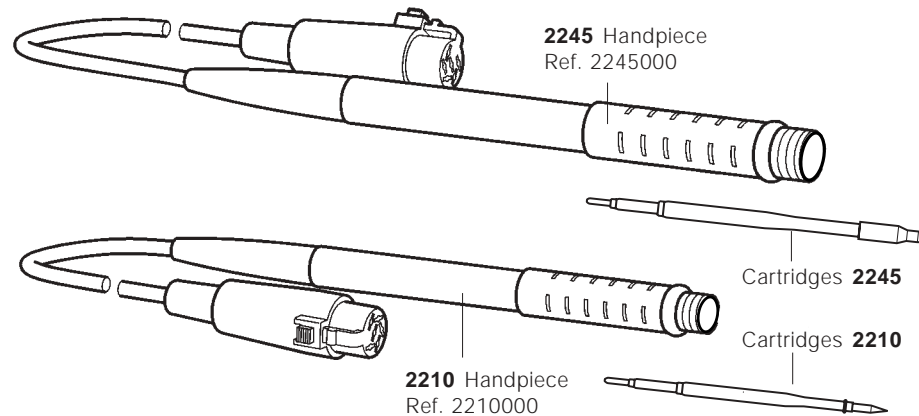

2245 Handpiece
Ref. 2245000

Cartridges 2245

Cartridges 2210

2210 Handpiece
Ref. 2210000

0455430-1

http://www.jbctools.com e-mail:info@jbctools.com
Tel. +34 93 325 32 00 - Fax +34 93 424 93 01
Vilamari, 50 - 08015 BARCELONA - SPAIN
JBC Industries, S.A.
MANUFACTURED BY

ADVANCED
SERIES



SOLDERING
HANDPIECES

2210
2245

RANGE OF CARTRIDGES

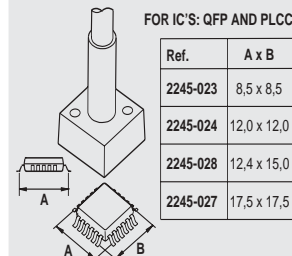
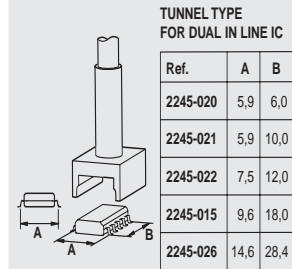
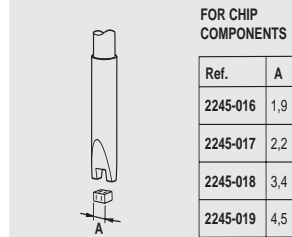
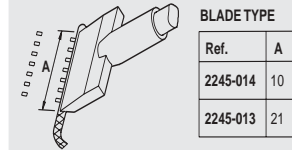
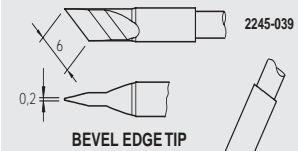
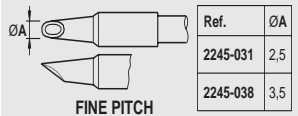
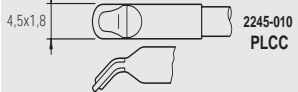
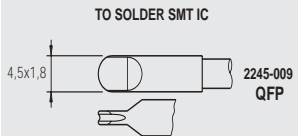

2210

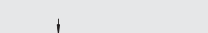
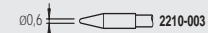
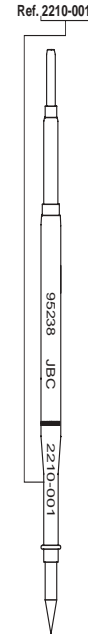

* The total length of these cartridges is 20mm longer in order to reach areas of difficult access.

All the cartridges shown are actual size.

PATENT PENDING



WARRANTY

ENGLISH

The JBC 2 years warranty, guarantees this equipment against all manufacturing defects, covering the replacement of defective parts and all necessary labour.

Malfunctions caused by misuse are not covered.

In order for the warranty to be valid, equipment must be returned, postage paid, to the dealer where it was purchased enclosing this, fully filled in, sheet.

GARANTIA

ESPAÑOL

JBC garantiza este aparato durante 2 años, contra todo defecto de fabricación, cubriendo la reparación con sustitución de las piezas defectuosas e incluyendo la mano de obra necesaria.

Quedan excluidas de esta garantía las averías provocadas por mal uso del aparato.

Es indispensable para acogerse a esta garantía el envío del aparato al distribuidor donde se adquirió, a portes pagados, adjuntando esta hoja debidamente cumplimentada.

GARANTIE

FRANÇAIS

JBC garantit cet appareil 2 ans contre tout défaut de fabrication. Cela comprend la réparation, le remplacement des pièces défectueuses et la main d'oeuvre nécessaire.

Sont exclues de cette garantie les pannes provoquées par une mauvaise utilisation de l'appareil.

Pour bénéficier de cette garantie il est indispensable d'envoyer l'appareil chez le distributeur où il a été acquis, en ports payés, en joignant cette fiche dûment remplie.

